



Community Development / Streets and Utilities

MEETING AGENDA

Berryville-Clarke County Government Center  
101 Chalmers Court, Second Floor  
AB Meeting Room  
Regular Session

February 24, 2026

3:30 PM

Item	Page
<b>1. Call to Order</b>	
<b>2. Approval of Agenda</b>	
<b>3. Unfinished Business</b>	
Updates on parking lot renovations and lighting in lots/parks.	2
Updates on the Service Line Warrenty Program	8
Update on Livery Renovation	
Update on Sidewalk Projects and Wayfinding Signs	17
Update on Glo Fiber and Verizon installation dates	
Update on Rose Hill Park Bridge	
<b>4. New Business</b>	
Reduce Speed Limit on Buckmarsh at Rt7 and Mosby Blvd	18
VCA Creative Communities Partnership Grants	19
<b>5. Other</b>	
<b>6. Closed Session</b>	
<b>7. Adjourn</b>	

**Item Title**

John Rixey Moore Municipal Parking Lot

**Prepared By**

Jean Petti

---

**Background/History/General Information**

John Rixey Moore Municipal Parking Lot offers forty-one unmetered parking spaces and two handicapped spaces. It was previously served by two lights, one of which was damaged and subsequently removed.

**Findings/Current Activity**

Trump's Electrical, a Berryville-based electrical company, has begun electrical service and lighting improvements. The lot sign has been moved closer to the street, an electrical backboard will be installed behind it, new conduit will be established down the middle of the lot, two new double-headed poles will be erected, and a new park light (to match existing) will be installed close to the basketball courts.

**Schedule/Deadlines**

The electrical and lighting upgrade is expected to wrap up by early summer. Lot repaving is being considered as part of 2026 asphalt work, but final scheduling will be dependent on overall budgetary limitations.

**Attachments**

Detail of pole structure and lighting map

**Recommendation**

None. Information only

# TOWN OF BERRYVILLE

## Table of Contents

1. Site Design Information
  - Site Location
  - Calculation Summary
  - Luminaire Schedule
  - Luminaire Location Summary
2. Screenshot
3. Luminaire Coordinates

## Created By

Jesse ABey  
 jabey@chesapeake-lighting.com  
 2025-12-08 3:44 PM

Location	Latitude	Longitude
100 S Church St, Berryville, VA 22611, USA	39.15003392692952	-77.98167308022111

## Calculation Summary

Stat Area	Calc Type	Units	Avg	Max	Min	Avg/Min	Max/Min
Stat Area 1	Illuminance	FC	2.25	20.75	0.03	75.0	691.67

## Luminaire Schedule

Label	Luminaire Name	Catalog No	Qty	Config	Luminaire Watts	Config Watts	Lumens	LLF	MH
A	EMM2 Epic	EMM2-HTN-SA2B-740-U-T3_12883 lumens	2	2 @ 180°	90.0W	180W	12,883.7	0.912	14 ft
B	EMM2 Epic	EMM2-HSN-SA2B-740-U-T5W_13263 lumens	2	Single	90.0W	90W	13,263	0.912	14 ft
<b>Total</b>			6 Fixtures		540		78,058		

## Luminaire Location Summary

Loc	Luminaire	Heads	X	Y	Z	Orient	Tilt
1	EMM2-HTN-SA2B-740-U-T3_12883 lumens	2	374.05 '	263.49 '	14 '	35°	0°
2	EMM2-HTN-SA2B-740-U-T3_12883 lumens	2	302.77 '	209.23 '	14 '	35°	0°
3	EMM2-HSN-SA2B-740-U-T5W_13263 lumens	1	453.07 '	258.55 '	14 '	305°	0°
4	EMM2-HSN-SA2B-740-U-T5W_13263 lumens	1	400.76 '	331.02 '	14 '	305°	NaN°

Connected Lighting Systems from Cooper Lighting Solutions such as WaveLinx, Trellix, and Telensa can enable code compliance and IoT-enabled applications.

Learn more at [Smart IOT Spaces](#)

0

482'

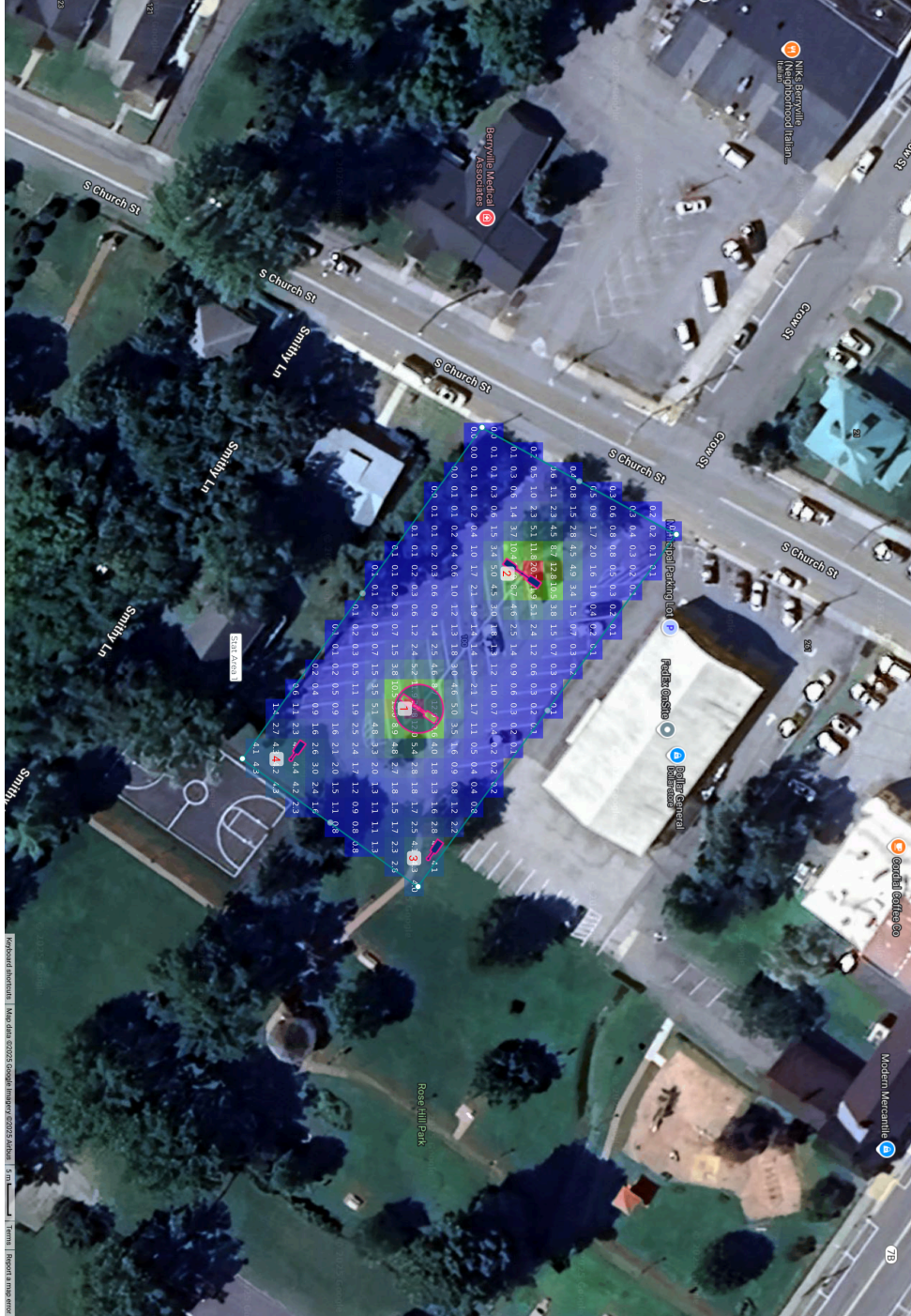

696'

2025-12-08 3:44 PM

Grid dimensions: 10' x 10'

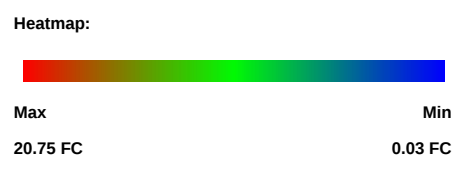

### Luminaire Coordinates

Loc	Luminaire	Latitude	Longitude
1	EMM2-HTN-SA2B-740-U-T3_12883 lumens	39.1499720758832	-77.98158071393645
2	EMM2-HTN-SA2B-740-U-T3_12883 lumens	39.15012079876475	-77.98183266615546
3	EMM2-HSN-SA2B-740-U-T5W_13263 lumens	39.14998559615818	-77.98130141334212
4	EMM2-HSN-SA2B-740-U-T5W_13263 lumens	39.14978695185737	-77.98148631033575

### Pole Luminaire Configuration

Label	Sport	Standard Design Name	Pole ID	Heads	X	Y	Z
-------	-------	----------------------	---------	-------	---	---	---

DISCLAIMER: This information shall be used for budgetary purposes only. The design and calculations previewed do not reflect obstructions of the illumination of the placed luminaire markers. Also, the calculations do not take into consideration irregularities at the illumination surface. Therefore, it is highly recommended that a full lighting layout be performed by professional lighting applications services. Please contact your Cooper Lighting Solutions representative for more information.

## Installation Overview

1. Align grooves and remove rotate cover.
2. Install rotate cover to arm. Torque to 40 in-lbs.
3. Hang fixture by cable and make electrical connections.
4. Push excess wire into bishop pole. Align grooves.
5. Lift fixture and twist until grooves are not aligned and STREET SIDE LABEL on bottom of fixture is towards the street.
6. Tighten set screws (4). Torque to 15 in-lbs or about equal to the torque using the short end of the allen wrench. Do Not Over Tighten.
7. Service cover. Loosen captive screws and lift to service the Surge, PCR, and FADC.

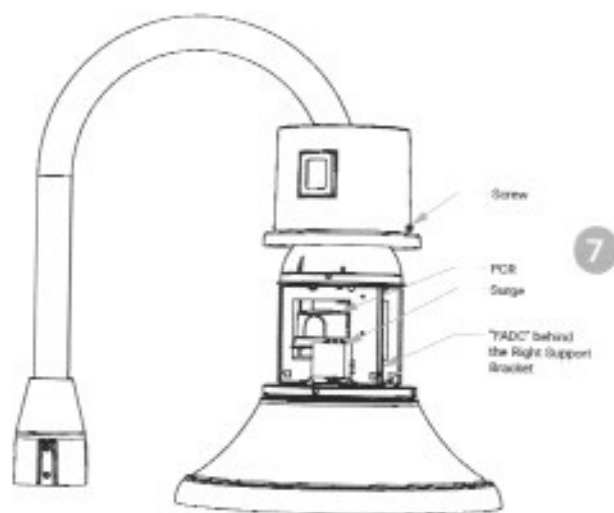
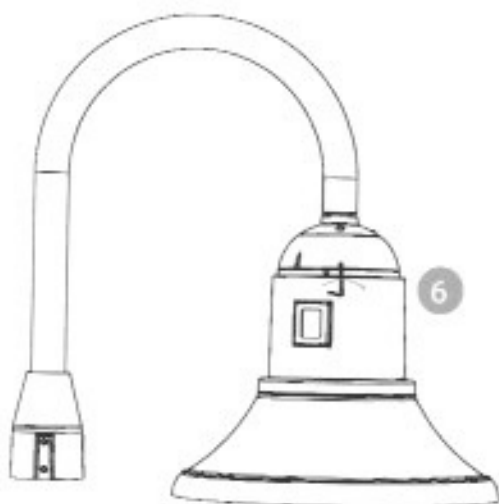
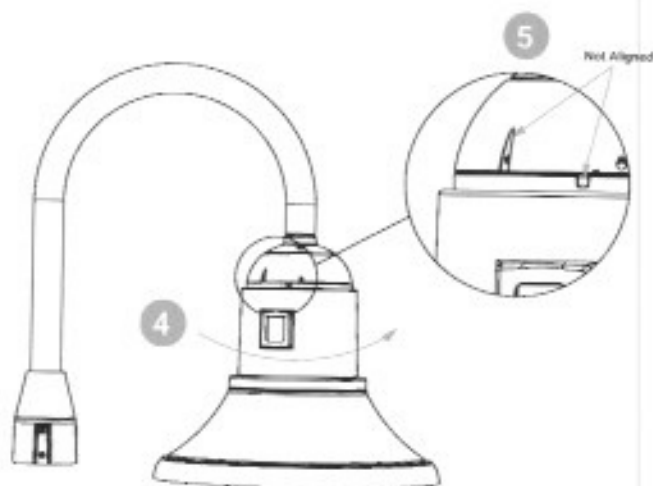

DWG NO: CPS-44011-14  
 TITLE:   
 CATALOG:   
 2017 Greedbeck Hwy. Warren, MI 48088  
 F: (586) 774-6105 | E: (586) 774-5706  
 www.generalstructuresinc.com  
 GENERAL STRUCTURES INC

2017 Greedbeck Hwy. Warren, MI 48088  
 F: (586) 774-6105 | E: (586) 774-5706  
 www.generalstructuresinc.com  
 GENERAL STRUCTURES INC

SCALE: NONE  
 S.O.#:  
 QUOTE:  
 APPROVED:  
 REVISION:  
 CHECKED:  
 DRAWN: M. HARWALA  
 DATE: 2/18/2015  
 REF:   
 270° 90°  
 HANDHOLE

POLE SPECIFICATIONS		MIN. YIELD (P.S.I.)	
NO.	COMPONENT	ASTM DESIGNATION	
1	POLE SHAFT	A-500 GR. B	46,000
2	BASE PLATE	A36	36,000
3	ANCHOR BOLTS	F1554 GR. 55	55,000
4	GALVANIZED HARDWARE	A163	

POLES SHALL HAVE A POLYESTER POWDER COAT FINISH IN A STANDARD COLOR.  
 SOLE DIMENSIONS

POLE HGT. (FT.)	TOP DIA. (IN.)	BOTTOM DIA. (IN.)	GAUGE	HTG. HGT. (FT.)
14'	4.00	4.00	11 GAUGE	34"

BASE PLATE DIMENSIONS

PLATE THICK. (IN.)	PLATE THICK. (IN.)
8.00-9.00	8.00 SQ.

ANCHOR BOLT DIMENSIONS

ANCHOR BOLT DIA. (IN.)	ANCHOR BOLT LENGTH (IN.)
.75	20.00

ALLOWABLE WIND LOADINGS (SQ. FT.)

WIND* EPA	80 MPH	90 MPH	100 MPH	120 MPH	4.0
	11.7	8.9	7.1		

\*WITH 1.3 GUST FACTOR

2.00 X 4.00 HAND HOLE COVER

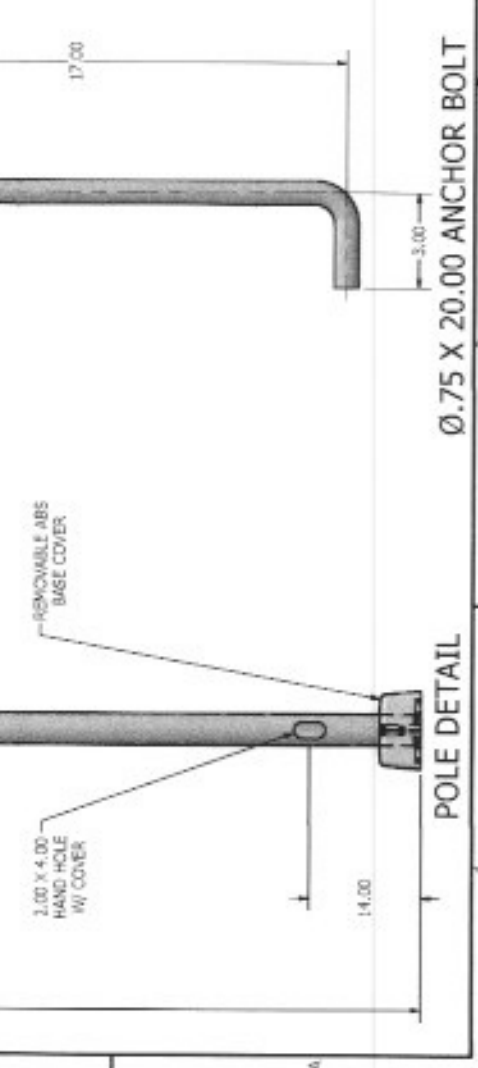
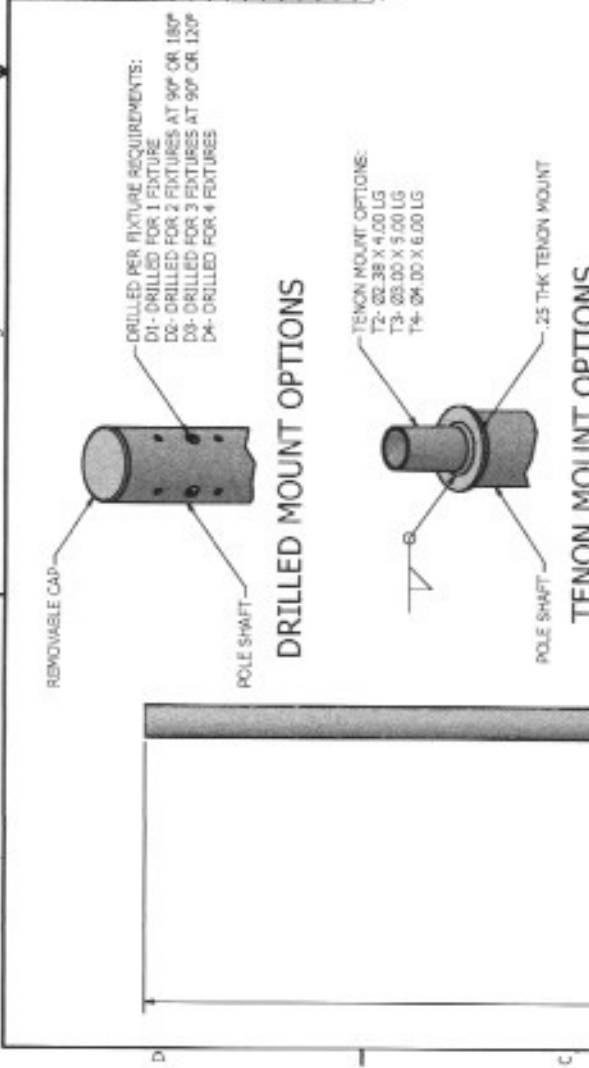
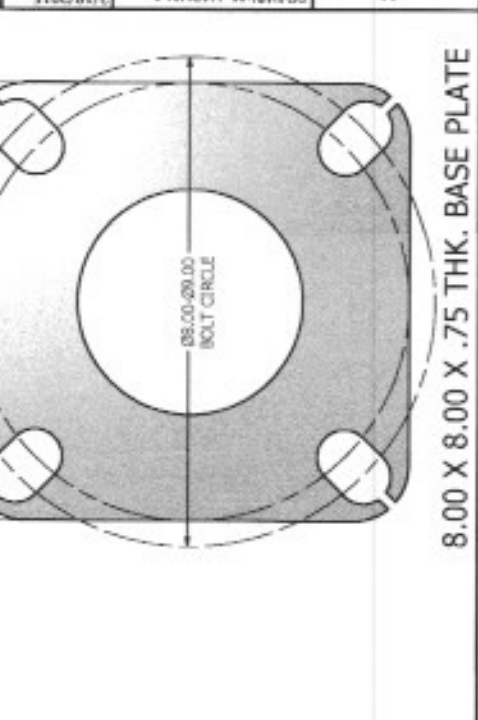
**Item Title**

Service Line Warranty

**Prepared By**

Jean Petti

---

**Background:** below is an excerpt from the minutes of November 2025.

*The first item of new business was consideration of a Service Line Warranty program. The Town was approached by Home Serve to endorse a marketing campaign for utility customers who may be interested in insuring their water and sewer lines against blockages and breakage. Mr. Perez noted a desire to explore more thoroughly the quality of customer service that participants experience and Mr. Tibbens concurred. Both council members expressed reservations about endorsement, with Mr. Tibbens suggesting that educating utility customers about the availability of such programs without endorsing one may be more appropriate. Both Mr. Perez and Mr. Tibbens unequivocally rejected the optional royalty to the Town that is available under the program. Mr. Tibbens shared with the committee that he had discovered that insurance at the discounted rates was already available through Washington Gas. The committee directed staff to collect a review proof of what would be mailed to customers and prepare a draft of an educational notice that could be added to the Town website or included in a mailing that would not provide endorsement of any particular insurance vendor. The committee will consider these at the next regularly scheduled meeting.*

**Current activity:** Attached is a review proof of what would be mailed to customers. Below is a sample text that could be included in an upcoming newsletter and/or added to the Town website.

*By Town Code, property owners are responsible for repairs to the water service line between the water meter and the structure it serves and for the entirety of the sewer line from the structure to the sewer main. These repairs are often not covered under standard homeowner's insurance; please check your policy for details. There are third-party warranty programs available, as well as add-on insurance policies. Berryville encourages property owners to investigate and determine if such insurance/warranty program is an investment they would like to make. Berryville does not endorse any particular insurance or warranty provider.*

# Partner b&w logo

PRSRT STD  
U.S. POSTAGE  
**PAID**  
MAILED FROM  
ZIP CODE 33310  
PERMIT NO. 750



XXX



**CITY LOGO**

<<*City of City*>>  
<<*State*>>

Dear <<City of City>> Homeowner;

The <<City of City>> has partnered with Service Line Warranties of America (SLWA), a provider of home emergency repair solutions to homeowners nationwide, to offer <<Product Name>> to <<City>> homeowners.

Many homeowners are not aware that they are responsible for certain repairs; for example, many Americans don't know that they are responsible to pay for repairs to water service and sewer/septic lines on their private property. Many homeowners are not prepared to handle the high costs of unexpected water service or sewer/septic line breakdowns.

Optional plans from SLWA can help protect you from the potentially expensive repair costs of water and sewer/septic lines inside and outside your home.

The enclosed information is provided to help you decide whether a plan from SLWA is right for you.

Please visit [www.slwofa.com](http://www.slwofa.com) for frequently asked questions and links to additional information. You can also call SLWA toll-free at <<Phone>> for more information, to sign up for coverage, or to opt out of any future SLWA mailings.

<<The City of City>>

Code

Information for <<City Name>> Homeowners



Please reply by:  
<<Month X, XXXX>>

Dear <<Mr. Sample>>,

Many homeowners are not aware that repairs to the exterior water service or sewer/septic lines that run between your home and the public utility connection are the responsibility of the homeowner.

Water service and sewer/septic lines are subjected to changing soil conditions, ground shifting and corrosion—which may cause a breakdown without warning, leaving you responsible for the cost of repair or replacement. Replacement of these lines can be expensive—costing you thousands of dollars in unforeseen expenses.

<<The City of City>> has partnered with Service Line Warranties of America (SLWA) to help eligible homeowners be prepared and have the best possible service in the case of such an emergency. So you're invited to enroll in <<Product\_Name\_XXXXXXXXXXXX>> and <<Product\_Name\_XXXXXXXXXXXX>> from SLWA. Accept this *optional* coverage and you'll receive as many service calls as you need up to \$X,XXX per call for covered water service or well line repairs, and as many service calls as you need up to \$X,XXX per call for covered sewer/septic line repairs (30-day wait includes a money-back guarantee for both) and no deductible. You will also have access to a 24/7, 365-day-a-year emergency repair service hotline. Once you have made your service call, SLWA will take care of your covered repair, dispatching a qualified plumber to your home and paying the bill directly. Peace of mind starting for as little as \$X.XX per month. Your emergency is dealt with and your water service or sewer/septic line is back to normal.

In the event of an emergency, these plans can save you a significant amount of money and the time of finding a plumber, which can be difficult in the best of times. Having these plans also helps eliminate worry, as you can be sure of a professional job completed by local, licensed and insured plumbers. These are the only service line protection programs for homeowners fully supported by <<City Name>>.

Please take the time to read the information on the back of this letter. If you would like to sign up for a plan, simply complete and return the enclosed form or call toll-free 1-XXX-XXX-XXXX. We certainly hope that you never have an exterior water service or sewer/septic line emergency, but if you should ever have a problem, you'll be glad you're covered. These programs are managed by SLWA, and no public funds were used for the mailing of this letter.

For fastest processing, please visit [www.slwofa.com](http://www.slwofa.com).

Sincerely,

<<The City of City>>

Mailcode

RX4262\_Choice\_Blue\_Pack

RX

<<Disclosure>>

# What would you do in an exterior line emergency?

The illustration shows where things may go wrong with your exterior lines and how much a licensed and insured plumber would typically charge customers who don't have coverage. How would you cope if it happened to you? With coverage, it's not something to worry about; you'll have no bill to pay for covered repairs up to the service call benefit amount.

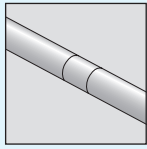

Replace water service line (26–100 ft.)  
**\$2,585**  
**Plan Members: No Charge†**

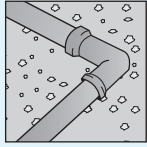

Replace sewer/septic line (26–75 ft.)  
**\$3,389**  
**Plan Members: No Charge†**

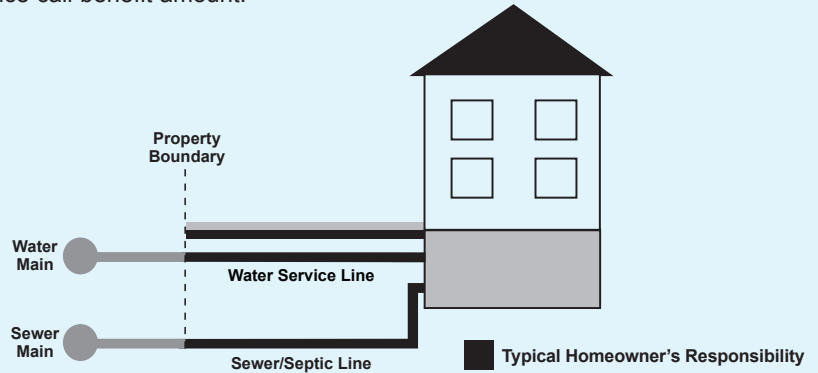

†National average repair costs within the SLWA network as of March 2018. No charge for covered repairs up to the service call benefit amount.

<<The water and sewer/septic lines beyond the <<property boundary>> may be an additional responsibility of the homeowner and are included in this coverage.>>  
 <<Septic tanks, leaching fields, pumps or grinders are not covered.>>

## Take A Look At The Benefits You'll Receive

Take A Look At The Benefits You'll Receive	<<Product Name>>	<<Product Name>>
1. <b>Covered Repairs</b> – Guaranteed for one full year.	✓	✓
2. <b>24-Hour Emergency Repair Service Hotline</b> – Open 24 hours a day, 365 days a year.	✓	✓
3. <b>Our Promise to You</b> – Simply call SLWA toll-free at 1-XXX-XXX-XXXX any time, and your coverage can be canceled at your request.	✓	✓

Visit [www.slwofa.com](http://www.slwofa.com) to protect your exterior lines  
 Or call toll-free 1-XXX-XXX-XXXX | Available: <<hours>>

## Important Questions & Answers

### What am I responsible for?

Nisit officii sintotatius et aturest emolore, ipitas dem et is exero con pa net, aspel exceptae.

### Does my homeowners insurance cover this?

Nisit officii sintotatius et aturest emolore, ipitas dem et is exero con pa net, aspel exceptae latrestis re dellaccus voles eosltam etur quam nonsequo volecus ea que omnis estius raest rem quidus, quia aut ea suntist. Henis eatios aliquatur. Agnis voloria nienihil invende.

### Does this coverage include well lines?

Henis eatios aliquatur. Agnis voloria nienihil invende.

### Who is eligible for coverage?

Nisit officii sintotatius et aturest emolore, ipitas dem et is exero con pa net, aspel exceptae latrestis re dellaccus voles eosltam etur quam nonsequo volecus ea que omnis estius raest rem quidus, quia aut ea suntist. Henis eatios aliquatur. Agnis voloria nienihil invendere dellaccus voles eosltam etur quam nonsequo volecus ea que omnis estius raest rem quidus, quia aut ea suntist. Henis eatios aliquatur. Agnis voloria nienihil invende nitates doluptam, que mi, voluptat et aspiducilic temod ut que et ant. Cersipientus solleniam, omnihit as dolo maximi, a ipsamet res sunt odi conse cori as Explignate cuptatem hilla eum con re quam faccumq.

### What should I know about this coverage?

**What's covered:** Nisit officii sintotatius et aturest emolore, ipitas dem et is exero con pa net, aspel exceptae latrestisisit officii sintotatius et aturest emolore, ipitas dem et is exero con pa net, aspel exceptae latrestis re dellaccus voles eosltam etur quam.

**Not covered:** Nisit officii sintotatius et aturest emolore, ipitas dem et is exero con pa net, aspel exceptae latrestisisit officii sintotatius et aturest emolore, ipitas dem et is exero con pa net, aspel exceptae latrestis re dellaccus voles eosltam etur quam nonsequo.

### When can I make a service call?

Nisit officii sintotatius et aturest emolore, ipitas dem et is exero con pa net, aspel exceptae latrestis re dellaccus voles eosltam etur quam nonsequo volecus ea que omnis estius raest rem quidus, quia aut ea suntist. Henis eatios aliquatur.

### What is the cancellation policy?

Nisit officii sintotatius et aturest emolore, ipitas dem et is exero con pa net, aspel exceptae latrestis re dellaccus voles eosltam etur quam nonsequo volecus ea que omnis estius raest rem quidus, quia aut ea suntist. Henis eatios aliquatur. Agnis voloria nienihil invende.

### What is the term of my service agreement?

Nisit officii sintotatius et aturest emolore, ipitas dem et is exero con pa net, aspel exceptae latrestis re dellaccus voles eosltam etur quam nonsequo volecus ea que omnis estius raest rem quidus, quia aut ea suntist. Henis eatios aliquatur. Agnis voloria nienihil invende.

### What is E-Z Pay/Direct Pay?

Nisit officii sintotatius et aturest emolore, ipitas dem et is exero con pa net, aspel exceptae latrestis re dellaccus voles eosltam etur quam nonsequo volecus ea que omnis estius raest rem quidus, quia aut ea suntist. Henis eatios aliquatur.

### What quality of repair can I expect?

Nisit officii sintotatius et aturest emolore, ipitas dem et is exero con pa net, aspel exceptae.

### Who is SLWA?

Nisit officii sintotatius et aturest emolore, ipitas dem et is exero con pa net, aspel exceptae latrestis re dellaccus voles eosltam etur quam nonsequo volecus ea que omnis estius raest rem quidus, quia aut ea suntist. dellaccus voles eosltam.



**Reminder: Please Reply by <<Month X, XXXX>>**



Dear <<Mr. Sample>>,

Many homeowners are not aware that repairs to the exterior water service or sewer/septic lines that run between your home and the public utility connection are the responsibility of the homeowner.

Water service and sewer/septic lines are subjected to changing soil conditions, ground shifting and corrosion—which may cause a breakdown without warning, leaving you responsible for the cost of repair or replacement. Replacement of these lines can be expensive—costing you thousands of dollars in unforeseen expenses.

<<The City of City>> has partnered with Service Line Warranties of America (SLWA) to help eligible homeowners be prepared and have the best possible service in the case of such an emergency. So you're invited to enroll in <<Product\_Name\_XXXXXXXXXXXX>> and <<Product\_Name\_XXXXXXXXXXXX>> from SLWA. Accept this *optional* coverage and you'll receive as many service calls as you need up to \$X,XXX per call for covered water service or well line repairs, and as many service calls as you need up to \$X,XXX per call for covered sewer/septic line repairs (30-day wait includes a money-back guarantee for both) and no deductible. You will also have access to a 24/7, 365-day-a-year emergency repair service hotline. Once you have made your service call, SLWA will take care of your covered repair, dispatching a qualified plumber to your home and paying the bill directly. Peace of mind starting for as little as \$X.XX per month. Your emergency is dealt with and your water service or sewer/septic line is back to normal.

In the event of an emergency, these plans can save you a significant amount of money and the time of finding a plumber, which can be difficult in the best of times. Having these plans also helps eliminate worry, as you can be sure of a professional job completed by local, licensed and insured plumbers. These are the only service line protection programs for homeowners fully supported by <<City Name>>.

Please take the time to read the information on the back of this letter. If you would like to sign up for a plan, simply complete and return the enclosed form or call toll-free 1-XXX-XXX-XXXX. We certainly hope that you never have an exterior water service or sewer/septic line emergency, but if you should ever have a problem, you'll be glad you're covered. These programs are managed by SLWA, and no public funds were used for the mailing of this letter.

For fastest processing, please visit [www.slwofa.com](http://www.slwofa.com).

Sincerely,

<<The City of City>>

Mailcode

RX4262\_Choice\_Blue\_Pack

RX

<<Disclosure>>

# What would you do in an exterior line emergency?

The illustration shows where things may go wrong with your exterior lines and how much a licensed and insured plumber would typically charge customers who don't have coverage. How would you cope if it happened to you? With coverage, it's not something to worry about; you'll have no bill to pay for covered repairs up to the service call benefit amount.

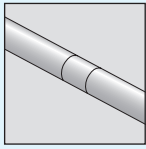

Replace water service line (26–100 ft.)  
**\$2,585**  
**Plan Members: No Charge†**

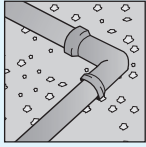

Replace sewer/septic line (26–75 ft.)  
**\$3,389**  
**Plan Members: No Charge†**

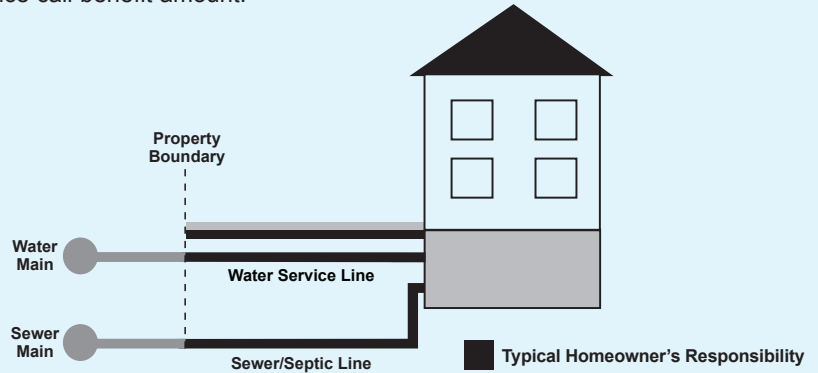

†National average repair costs within the SLWA network as of March 2018. No charge for covered repairs up to the service call benefit amount.

<<The water and sewer/septic lines beyond the <<property boundary>> may be an additional responsibility of the homeowner and are included in this coverage.>>  
 <<Septic tanks, leaching fields, pumps or grinders are not covered.>>

Take A Look At The Benefits You'll Receive	<<Product Name>>	<<Product Name>>
1. <b>Covered Repairs</b> – Guaranteed for one full year.	✓	✓
2. <b>24-Hour Emergency Repair Service Hotline</b> – Open 24 hours a day, 365 days a year.	✓	✓
3. <b>Our Promise to You</b> – Simply call SLWA toll-free at 1-XXX-XXX-XXXX any time, and your coverage can be canceled at your request.	✓	✓

**Visit [www.slwofa.com](http://www.slwofa.com) to protect your exterior lines**  
**Or call toll-free 1-XXX-XXX-XXXX | Available: <<hours>>**

## Important Questions & Answers

### What am I responsible for?

Nisit officii sintotatius et aturest emolore, ipitas dem et is exero con pa net, aspel exceptae.

### Does my homeowners insurance cover this?

Nisit officii sintotatius et aturest emolore, ipitas dem et is exero con pa net, aspel exceptae latrestis re dellaccus voles eosltam etur quam nonsequo volecus ea que omnis estius raest rem quidus, quia aut ea suntist. Henis eatios aliquatur. Agnis voloria nienihil invende.

### Does this coverage include well lines?

Henis eatios aliquatur. Agnis voloria nienihil invende.

### Who is eligible for coverage?

Nisit officii sintotatius et aturest emolore, ipitas dem et is exero con pa net, aspel exceptae latrestis re dellaccus voles eosltam etur quam nonsequo volecus ea que omnis estius raest rem quidus, quia aut ea suntist. Henis eatios aliquatur. Agnis voloria nienihil invendere dellaccus voles eosltam etur quam nonsequo volecus ea que omnis estius raest rem quidus, quia aut ea suntist. Henis eatios aliquatur. Agnis voloria nienihil invende nitates doluptam, que mi, voluptat et aspiducilic temod ut que et ant. Cerspientus solleniam, omnihit as dolo maximi, a ipsamet res sunt odi conse cori as Explignate cuptatem hilla eum con re quam faccumq.

### What should I know about this coverage?

**What's covered:** Nisit officii sintotatius et aturest emolore, ipitas dem et is exero con pa net, aspel exceptae latrestisisit officii sintotatius et aturest emolore, ipitas dem et is exero con pa net, aspel exceptae latrestis re dellaccus voles eosltam etur quam.

**Not covered:** Nisit officii sintotatius et aturest emolore, ipitas dem et is exero con pa net, aspel exceptae latrestisisit officii sintotatius et aturest emolore, ipitas dem et is exero con pa net, aspel exceptae latrestis re dellaccus voles eosltam etur quam nonsequo.

### When can I make a service call?

Nisit officii sintotatius et aturest emolore, ipitas dem et is exero con pa net, aspel exceptae latrestis re dellaccus voles eosltam etur quam nonsequo volecus ea que omnis estius raest rem quidus, quia aut ea suntist. Henis eatios aliquatur.

### What is the cancellation policy?

Nisit officii sintotatius et aturest emolore, ipitas dem et is exero con pa net, aspel exceptae latrestis re dellaccus voles eosltam etur quam nonsequo volecus ea que omnis estius raest rem quidus, quia aut ea suntist. Henis eatios aliquatur. Agnis voloria nienihil invende.

### What is the term of my service agreement?

Nisit officii sintotatius et aturest emolore, ipitas dem et is exero con pa net, aspel exceptae latrestis re dellaccus voles eosltam etur quam nonsequo volecus ea que omnis estius raest rem quidus, quia aut ea suntist. Henis eatios aliquatur. Agnis voloria nienihil invende.

### What is E-Z Pay/Direct Pay?

Nisit officii sintotatius et aturest emolore, ipitas dem et is exero con pa net, aspel exceptae latrestis re dellaccus voles eosltam etur quam nonsequo volecus ea que omnis estius raest rem quidus, quia aut ea suntist. Henis eatios aliquatur.

### What quality of repair can I expect?

Nisit officii sintotatius et aturest emolore, ipitas dem et is exero con pa net, aspel exceptae.

### Who is SLWA?

Nisit officii sintotatius et aturest emolore, ipitas dem et is exero con pa net, aspel exceptae latrestis re dellaccus voles eosltam etur quam nonsequo volecus ea que omnis estius raest rem quidus, quia aut ea suntist. dellaccus voles eosltam.



## Town Council Agenda Item Report Summary

February 24, 2026

### Item Title

Community Development Committee Update

### Prepared By

Terry Russell

---

### Planning Commission

The Christopher Cos, Inc., which has requested a rezoning of the Friant Property, has asked the Planning Commission to hold a second work session on the proposal at its meeting to be held on February 24, 2026 at 7:00 pm.

### Berryville Area Development Authority

The BADA will meet February 25, 2026 at 1:00 pm. They are continuing to work on the update of the Berryville Area Plan

### Wayfinding

Bids were opened on Thursday, February 12, 2026. FastSigns was the low bidder. Due to the high level of the bids, the Town has asked the low bidder to price a pared down program to include the four gateway signs and the parking signs only.

### East Fairfax Street and Mosby Boulevard Sidewalks

Imperio Construction has informed Town staff that construction will begin when the weather permits. They said the that the project should take about four to five weeks to complete once begun.

Code of Virginia  
Title 46.2. Motor Vehicles  
Subtitle III. Operation  
Chapter 8. Regulation of Traffic  
Article 8. Speed

## § 46.2-875. Maximum speed limit on certain other highways in cities and towns

The maximum speed limit shall be 35 miles per hour on highways in any city or town, except on interstate or other limited access highways with divided roadways and in business or residence districts. However, municipalities that maintain their own roads may increase or decrease speed limits on highways over which they have jurisdiction following appropriate traffic engineering investigation.

Code 1950, § 46-212; 1950, p. 881; 1952, c. 666; 1954, c. 244; 1956, c. 364; 1958, c. 541, § 46.1-193; 1960, c. 153; 1962, c. 307; 1964, cc. 118, 408; 1966, c. 85; 1968, c. 641; 1972, cc. 89, 546, 553, 608; 1974, c. 528; 1977, c. 577; 1978, c. 605; 1980, c. 347; 1989, c. 727; 2011, c. [182](#).

The chapters of the acts of assembly referenced in the historical citation at the end of this section(s) may not constitute a comprehensive list of such chapters and may exclude chapters whose provisions have expired.

# Community Development Committee Agenda Item Report Summary

February 24, 2026

## Item Title

Virginia Commission for the Arts Creative Communities Partnership Grant Applications

## Prepared By

Terry Russell

---

## Background/History/General Information

The Town of Berryville has applied for and received funds annually from the Virginia Commission for the Arts (VCA) since 2012 with the exception of 2019. The intent of the grant, now called the Creative Communities Partnership Grant, is to encourage local governments to support the arts. A line item totaling \$4,500 is included in the proposed budget. If approved, the grant is matched by the VCA in the same amount.

Additional information can be found at this link: <https://vca.virginia.gov/grant/creative-communities-partnership-grants/>.

## Findings/Current Activity

In 2021, the Community Development Committee recommended an application process through which the Town identifies local arts organizations who may want to benefit from the grant. Four grant applications were received for this cycle.

The Community Development Committee is tasked to review the applications. Committee members recommend to the Town Council which applications should receive grants and how much each applicant should be awarded. This year the Town has received applications from Barns of Rose Hill (requested \$4,500), Tiny Toes Dance (requested \$2,000), and SRSM Productions, LLC (producing the Watermelon Pickers' Fest) (requested \$4,500). Should the Town of Berryville receive the grant from the Virginia Commission for the Arts, the amounts identified will be doubled with their match.

## Schedule/Deadlines

A recommendation on subrecipients and amounts should be made at this meeting and forwarded to the Town Council for its meeting on March 10, 2026. The Creative Communities Partnership Grant application to the Virginia Commission on the Arts is due by April 1, 2026.

## Other Considerations

N/A

**Recommendation**

Discuss at the meeting and recommend subrecipients and amounts.

**Sample Motion**

I move that the Community Development Committee of the Council of the Town of Berryville recommend funding in the amount of \$ \_\_\_ for \_\_\_\_\_,

**Attachment**

VCA grant applications

Berryville – Clarke County  
Government Center  
101 Chalmers Court, Suite A  
Berryville, VA 22611



[T] 540/955-1099  
[F] 540/955-4524  
[E] info@berryvilleva.gov

**BERRYVILLE**  
EST. 1798 *Genuine* VIRGINIA

**Creative Communities Partnership Grant  
Participant Application**  
**Deadline: February 20, 2026**

PLEASE NOTE: applicants must be an organization whose primary purpose is the arts (production, presentation or support of dance, literary arts, media arts, music, theater, or visual or related arts), that are incorporated in Virginia. They must also have their headquarters and home seasons, or activities equivalent to a home season, within the state. Funding cannot be provided for payment to performers for specific performances. For more information about the Virginia Commission for the Arts' Creative Communities Partnership Grant program, please visit <https://vca.virginia.gov/grant/creative-communities-partnership-grants/>. Additional information can also be found on the Town of Berryville's web site at <http://berryvilleva.gov/>.

Name of Arts Organization: Barns of Rose Hill

Applicant Name: Reynolds Martha F.  
*Last First M.I.*

Address: 95 Chalmers Court PO Box 738  
*Street Address Apartment/Unit#*  
Berryville Virginia 22611  
*City State ZIP Code*

E-Mail: martha.reynolds@borh.org

Phone: (540) 955-2004

Has this organization received a Local Arts Grant from the Town of Berryville in the past?

Yes  No

Grant amount requested: (maximum \$4,500) \$4,500

**Harry Lee Arnold, Jr.**  
*Mayor*

**Erecka L. Gibson**  
*Vice Mayor*

*Council Members*

**William Steinmetz**  
*Ward 1*

**Paul Perez**  
*Ward 2*

**Grant Mazzarino**  
*Ward 3*

**Ryan Tibbens**  
*Ward 4*

**Keith R. Dalton**  
*Town Manager*

**Please give a brief description of the organization, proposed project, and who will participate.**

Barns of Rose Hill is a 501(c)(3) nonprofit arts and community center located in downtown Berryville in Clarke County, Virginia. Founded in 2004, the organization began with a bold community vision: to preserve and transform two deteriorating dairy barns into a permanent home for the arts. After six years of fundraising, planning, and renovation—driven largely by local support—the Barns opened its doors in 2011. Now, nearly fifteen years later, it stands as a thriving cultural anchor reflective of both Berryville’s heritage and its creative future.

In keeping with our mission to enrich lives through the arts, education, and community engagement, the Barns presents year-round programming spanning the performing, visual, and literary arts, along with two rotating art galleries. In the past year, we delivered approximately 140 programs, including concerts, exhibitions, film screenings, lectures, and hands-on workshops. Roughly one quarter of these programs were offered free of charge, ensuring that residents of all ages can participate regardless of financial circumstance. This balance between access and sustainability remains central to our mission and is made possible by the Town’s continued investment in local arts and culture.

In the coming year, our work will be defined by deeper collaboration and more intentional engagement. As an active partner in Clarke County’s VA250 Committee, the Barns will collaborate with fellow members and other local organizations to explore the nation’s semiquincentennial through artistic interpretation, historical reflection, and civic dialogue. By anchoring these commemorative efforts in the arts, we aim to create programs that are not only informative, but also participatory and locally resonant.

We are also expanding our interactive arts model by pairing exhibitions by regional artists with complementary classes, artist talks, and facilitated discussions. Rather than presenting visual art as a stand-alone experience, we are creating opportunities for the public to respond, experiment, and create alongside exhibiting artists. This layered approach strengthens the relationship between artist and audience while fostering creativity, critical thinking, and meaningful exchange.

As the Berryville-Clarke County Visitors Center, the Barns further contributes to the region’s economic vitality by attracting audiences who support nearby businesses and attractions. Support from the Town enables us to sustain accessible programming, compensate artists fairly, and invest in collaborative initiatives that enrich both the cultural and civic life of Berryville residents, who comprise nearly 20% of our audience and regularly participate in programs across all disciplines.

Rooted in preservation, sustained by community support, and continually evolving to meet emerging opportunities, the Barns of Rose Hill remains committed to bringing people together through shared creative experiences that reflect and strengthen local identity and connection.

**Please list the organization’s officers, board of directors, and key staff as applicable.**

**Board of Directors**

Bruce Ruscio, <i>Board Chair</i>	Allen Kitselman
Kelli Patterson, <i>Vice Chair &amp; Treasurer</i>	Jennifer Lee
Patricia Castelhana, <i>Secretary</i>	Jordan Liskey
Susan Bailey	Ronald "JC" Moore
Margaret Bauman	Paul Perez
Alice Irvan	Jim Waters
Erika Kelble	

**Staff**

Martha Reynolds, *Executive Director*  
Nathan Borger, *Director of Operations and Programs*  
Jillian Cash, *Visitor Services Associate*

### **How will the community benefit from the project?**

The Barns of Rose Hill provides wide-ranging benefits to the Town of Berryville, Clarke County, and the surrounding Northern Shenandoah Valley by serving as a consistent, accessible hub for arts engagement, civic connection, and economic activity. Through year-round programming—including live performances, visual art exhibitions, film screenings, workshops, and community events—the Barns creates opportunities for residents to gather, learn, and participate in shared cultural experiences, strengthening community ties while contributing to local vitality.

In the coming year, the Barns anticipates presenting over 100 arts and community programs. Roughly one quarter will be offered free of charge, with the remainder priced affordably to ensure broad access. This is especially meaningful in a rural region where arts and educational opportunities are less abundant than in urban areas, allowing residents to experience high-quality cultural offerings close to home.

A central focus of our plans for the coming year is enhancing engagement. By pairing visual art exhibitions with artist talks, classes, and participatory workshops, the Barns hopes to inspire audiences to respond to and create alongside local and regional artists. These interactive opportunities foster creativity, confidence, and dialogue, while strengthening connections between artists and the community. For residents, this means not only access to high-quality arts experiences, but also opportunities for hands-on learning and shared discovery.

Collaboration further amplifies community benefit. As an active partner in Clarke County's VA250 Committee, the Barns will work with local organizations to develop arts-centered programs that explore the nation's sesquicentennial through local history, storytelling, and civic reflection. These initiatives will help ensure that national commemoration is grounded in local perspective, highlighting Berryville's own historical and cultural narratives while encouraging civic reflection and intergenerational engagement.

The Barns also supports the local economy. As the official Visitors Center for Berryville and Clarke County—and a tourist destination in our own right—we draw and engage audiences who patronize nearby restaurants, shops, and attractions. Berryville residents represent nearly 20% of overall attendance, while out-of-town visitors help sustain foot traffic in the downtown corridor—reinforcing the Town's investment in a vibrant and active community center.

Support from the Town of Berryville enables the Barns to maintain accessible programming, fairly compensate artists—many of whom are local and reinvest in the community—and leverage matching support from the Virginia Commission for the Arts. This partnership ensures that the impact of municipal funding is multiplied, sustaining a cultural resource that strengthens quality of life, civic identity, and economic activity.

An investment in the Barns of Rose Hill is an investment in Berryville itself: in civic life, cultural opportunity, local collaboration, and economic vitality. Through accessible, engaging, and place-based arts programming, the Barns looks forward to continuing to enrich the lives of those who live, work, and visit here.

**Please attach the organization's budget.**

*\*See attached.*

Please select the category that best describes your organization's primary focus.

- Arts Education
- Dance
- Multidisciplinary
- Music
- Opera
- Theater/Storytelling
- Visual Arts
- Other (please describe) \_\_\_\_\_

**Populations Benefitted**

Please select any categories that, by your best estimate, will make up 25% or more of the population that will directly benefit from the award during the period of support.

**Racial or Ethnic Groups**

- American Indian/Alaskan
- Hispanic/Latino
- Asian/Pacific Islander
- White/Caucasian
- Black/African American
- Other

**Other Distinct Groups**

- Individuals with disabilities
- Individuals with limited English proficiency
- Individuals in institutions (hospitals, hospices, assisted care, etc.)
- Military veterans/active duty personnel
- Individuals below the poverty line
- Youth at risk

**Age**

- Children/Youth (0-18 years)
- Young adults (19-24 years)
- Adults (25-64)
- Older adults (65+ years)

**Arts Education** Choose the one item which best describes the funded activities.

- 50% or more of the funded activities are arts education directed to K through 12 students, higher education students, pre-kindergarten children, and/or adult learners (including teachers and artists)
- Less than 50% of the funded activities are arts education directed to K through 12 students, higher education students, pre-kindergarten children, and/or adult learners (including teachers and artists)
- None of the funded activities involve arts education

*Martha Reynolds*

2/19/2026

Signature

Date

**Barns of Rose Hill  
2026 Annual Budget**

**REVENUE**

Programming Revenue	
Performances & Films	\$ 146,610.00
Educational Workshop	\$ 15,250.00
Art Exhibits	\$ 7,500.00
Gift Shop Revenue	\$ 5,600.00
Program Sponsorship	\$ 22,500.00
Total Programming Revenue	<u>\$ 197,460.00</u>
Other Revenue (temp. restricted investments)	\$ 75,880.00
Development Revenue	
General Donations	\$ 130,000.00
Brick Sales	\$ 3,000.00
Memberships	\$ 15,500.00
Total Development Revenue	<u>\$ 148,500.00</u>
Special Events	\$ 52,250.00
Grants & Restricted Donations	
Grants	\$ 40,000.00
Restricted Donations (endowment)	\$ 200,000.00
Total Grants & Restricted Donations	<u>\$ 240,000.00</u>
Property Rental Revenue	\$ 8,750.00
<b>TOTAL REVENUE</b>	<u><b>\$ 722,840.00</b></u>

**EXPENSES**

Program Service Expenses	
Performances & Films	\$ 115,249.00
Educational Workshops	\$ 13,950.00
Art Exhibit Costs	\$ 5,750.00
Gift Shop Expense	\$ 4,000.00
Other Programming Expenses	\$ 32,630.00
Total Program Service Expenses	<u>\$ 171,579.00</u>
Other Expenses	
Compensation	\$ 162,494.77
Professional Fees	\$ 22,250.00
Occupancy Expenses	\$ 64,848.82
Office Expenses	\$ 19,750.00
General Expenses	\$ 43,050.00
Development/Outreach Expense	\$ 8,000.00
Fundraising Events	\$ 14,000.00
Total Other Expenses	<u>\$ 335,993.59</u>
<b>TOTAL EXPENSES</b>	<u><b>\$ 507,572.59</b></u>

<b>CHANGE IN NET ASSETS</b>	<b>\$ 215,267.41</b>
Less Permanently Restricted Donations (endowment)	\$ (200,000.00)
Less Temporarily Restricted (investments)	\$ (77,500.00)
Add Transfer from Endowment	\$ 63,000.00
Net in Unrestricted Net Assets	<b>\$ 767.41</b>

Berryville – Clarke County  
Government Center  
101 Chalmers Court, Suite A  
Berryville, VA 22611



[T] 540/955-1099  
[F] 540/955-4524  
[E] info@berryvilleva.gov  
www.berryvilleva.gov

**BERRYVILLE**  
EST. 1798 *Genuine* VIRGINIA

**Creative Communities Partnership Grant  
Participant Application**  
**Deadline: February 20, 2026**

PLEASE NOTE: applicants must be an organization whose primary purpose is the arts (production, presentation or support of dance, literary arts, media arts, music, theater, or visual or related arts), that are incorporated in Virginia. They must also have their headquarters and home seasons, or activities equivalent to a home season, within the state. Funding cannot be provided for payment to performers for specific performances. For more information about the Virginia Commission for the Arts' Creative Communities Partnership Grant program, please visit <https://vca.virginia.gov/grant/creative-communities-partnership-grants/> . Additional information can also be found on the Town of Berryville's web site at <http://berryvilleva.gov/>.

Name of Arts Organization: Tiny Toes Dance, LLC

Applicant Name: Tibbens Ashley M  
*Last First M.I.*

Address: 307 Stuart Ct  
*Street Address Apartment/Unit#*  
Berryville VA 22611  
*City State ZIP Code*

E-Mail: Ashley@TinyToesDance.com

Phone: 703-989-3413

Has this organization received a Local Arts Grant from the Town of Berryville in the past?

m  Yes m No

Grant amount requested: (maximum \$4,500) \$2,000

Please provide a brief description of the organization:

Mayor Harry Lee Arnold, Jr. Vice Mayor Erecka L. Gibson  
Council Members  
William Steinmetz Paul Perez Grant Mazzarino Ryan Tibbens  
Ward 1 Ward 2 Ward 3 Ward 4  
Keith R. Dalton  
Town Manager

**Please give a brief description of the organization, proposed project, and who will participate.**

Tiny Toes Dance is a youth-focused dance education program serving children ages 18 months through 15 years throughout Clarke County and surrounding communities. Our mission is to build confidence, creativity, discipline, and joy through high-quality, age-appropriate dance instruction. We provide accessible arts education opportunities both in studio settings and through partnerships with local schools and community organizations.

The proposed project will provide structured dance instruction for students ages 18 months–15 years, culminating in community-based performance opportunities that showcase local youth talent. Instruction focuses on foundational movement skills, coordination, musicality, teamwork, and performance confidence, with curriculum tailored to each developmental stage — from toddler creative movement to elementary and middle school-level technique.

A key component of this project is community engagement through free public performances at local events hosted by Berryville Main Street, including parades, Fall in the Park, and the annual Tree Lighting event. These performances are provided at no cost to participating students, ensuring equitable access to meaningful stage experiences. Participants include local children and teens, their families, and the broader community who attend these public celebrations.

**Please list the organization’s officers, board of directors, and key staff as applicable.**

**Founder & Program Director:**

Ashley Tibbens – Owner and Director of Tiny Toes Dance. Ashley oversees curriculum development, instructor training, community partnerships, performance coordination, and overall program implementation.

**Key Staff & Instructors:**

Tiny Toes Dance employs trained and background-checked dance instructors who specialize in early childhood and youth dance education. Staff are experienced in developmentally appropriate instruction, classroom management, choreography, and preparing students for both studio and community performances.

Tiny Toes Dance is a privately owned small business and does not currently operate under a formal board of directors.

**How will the community benefit from the project?**

This project enhances community cultural life by increasing access to arts education and public performance opportunities for local youth. Dance education supports physical development, confidence, creative expression, teamwork, and discipline, while also fostering social connection among students and families.

**Measurable Goals & Outcomes:**

- To demonstrate impact, Tiny Toes Dance will achieve the following measurable outcomes during the grant period:
- Serve at least 50 students per month across a diverse age range (18 months–15 years) with dance instruction that builds skills and confidence.
- Deliver at least 5 free community performances at local events (including parades, Fall in the Park, and Tree Lighting), providing students with public stage experience and enhancing town arts offerings.
- Generate a positive financial impact for Clarke County Parks & Recreation, contributing at least \$500 per month through class revenues and facility use fees that support the county’s recreation programs and facilities.
- Engage community audiences of 1,000+ residents at public performances, increasing awareness and appreciation for youth arts participation.
- Increase participation among under-represented families by offering scholarship opportunities and outreach to ensure broad access to the arts.

These outcomes reflect Tiny Toes Dance’s commitment to artistic excellence, operational strength, and community engagement — priorities that align with the Virginia Commission for the Arts Community Impact Grant criteria, including fostering arts experiences that are innovative, accessible, and deeply rooted in community participation.

**Please attach the organization’s budget.**

Attached

Please select the category that best describes your organization's primary focus.

Arts Education

Dance

Multidisciplinary

Music

Opera

Theater/Storytelling

Visual Arts

Other (please describe) \_\_\_\_\_

### Populations Benefitted

Please select any categories that, by your best estimate, will make up 25% or more of the population that will directly benefit from the award during the period of support.

### Racial or Ethnic Groups

American Indian/Alaskan

Asian/Pacific Islander

Black/African American

Hispanic/Latino

White/Caucasian

Other

### Other Distinct Groups

Individuals with disabilities

Individuals in institutions

Individuals below the

(hospitals, hospices, assisted care, etc.) poverty line

Individuals with limited English proficiency

Military veterans/active duty personnel

Youth at risk

### Age

Children/Youth (0-18 years)

Adults (25-64)

Young adults (19-24 years)

Older adults (65+ years)

**Arts Education** Choose the one item which best describes the funded activities.

- 50% or more of the funded activities are arts education directed to K through 12 students, higher education students, pre-kindergarten children, and/or adult learners (including teachers and artists)
- Less than 50% of the funded activities are arts education directed to K through 12 students, higher education students, pre-kindergarten children, and/or adult learners (including teachers and artists)
- None of the funded activities involve arts education

*Ashley Tibbens*

2/18/2026

Signature

Date

## Tiny Toes Dance – Town of Berryville Program Budget

### Income

- Berryville Class Revenue (annual): **\$10,465.60**
- Additional Monthly Class Revenue ( $\$500 \times 12$ ): **\$6,000**

**Total Earned Income: \$16,465.60**

### Personnel Expense

- Instructor Payroll ( $\$1,000 \times 12$ ): **\$12,000**

### Facility Fees Expense

- Clarke County Parks & Recreation ( $\$250 \times 12$ ): **\$3,000**

### Program & Performance Expenses (Estimated)

- Costumes, music licensing, props, rehearsal materials, performance production: **\$3,000**

**Total Annual Expenses: \$18,000**

---

### Operating Gap

**Total Income: \$16,465.60**

**Total Expenses: \$18,000**

**Annual Gap: \$1,534.40**

Tiny Toes Dance generates approximately \$16,465.60 annually in earned income from classes offered in the Town of Berryville. These funds directly support arts education programming for children ages 18 months–15 years.

Annual program expenses total approximately \$18,000. Personnel costs represent \$12,000 annually to compensate qualified instructors who provide consistent, developmentally appropriate dance instruction. Facility fees paid to Clarke County Parks & Recreation total approximately \$3,000 per year, directly supporting county recreation infrastructure. An additional \$3,000 supports costumes, music licensing, rehearsal materials, and community performance production expenses.

The modest annual operating gap of \$1,534.40 reflects the organization's commitment to maintaining affordable tuition rates while providing free public performances at community events. Grant funding will ensure program stability, sustain instructor compensation, and allow Tiny Toes Dance to continue offering accessible arts experiences for local youth and families.

## Terry Russell

---

**From:** Stacey Sinclair <staceyraesinclair@gmail.com>  
**Sent:** Sunday, February 15, 2026 10:04 AM  
**To:** Terry Russell  
**Subject:** VCA Creative Communities Partnership Grant – Watermelon Pickers’ Fest Application  
**Attachments:** TOB VCA grant application 2026\_202602031506513090 (1).pdf; Watermelon Pickers’ Fest – Project Budget Summary – 2026.pdf

CAUTION: This email originated from outside your organization. Exercise caution when opening attachments or clicking links, especially from unknown senders.

Dear Terry Russell:

I’m writing to share the Watermelon Pickers’ Fest application and budget materials for the VCA Creative Communities Partnership Grant. This request supports the festival’s arts education and community programming, including hands-on music and dance workshops, youth-focused learning opportunities, and collaborative experiences designed to engage participants of all ages and skill levels.

We are grateful for the Town of Berryville’s continued commitment to strengthening arts and culture in our community and appreciate your consideration of this proposal. Please let me know if you need any additional information.

Warmly,  
Stacey Sinclair  
Watermelon Pickers’ Fest

--  
Stacey Sinclair  
[www.watermelonpickersfest.com](http://www.watermelonpickersfest.com)  
703-475-7014





**Please give a brief description of the organization, proposed project, and who will participate.**

The Watermelon Pickers' Fest is a three-day bluegrass, old-time, folk, roots, and Americana music festival held annually in Berryville, Virginia. Hosted in Clarke County, the festival brings a diverse lineup of world-class performers to the community while fostering meaningful cultural exchange. The festival intentionally engages a broad and inclusive range of artists, highlighting women and performers of color whose contributions are essential to American roots music. Central to its mission is closing the gap between artist and audience through intimate performances, hands-on instrumental and dance workshops, collaborative jam sessions, and family-friendly programming that welcomes musicians and learners of all ages and skill levels. By pairing high-quality performances with participatory learning experiences, the festival strengthens cultural vitality in Berryville and supports local artisans and vendors while welcoming more than 1,000 attendees each year.

**Please list the organization's officers, board of directors, and key staff as applicable.**

**Key Staff:**

- Stacey Sinclair: Producing Director
- John Bryant: Logistics and Production
- Katie Priest: Artist and Vendor Liaison
- Tom Gill: Site Ops and Staff Coordinator

**How will the community benefit from the project?**

This project will provide meaningful cultural and educational benefits to the community through accessible music and dance workshops designed for all ages and skill levels, from beginners to experienced musicians. By maintaining a long-standing commitment that children under 12 are admitted free, the festival ensures that young people can experience live roots music, participate in hands-on learning, and develop an early connection to the arts. Community members will have the opportunity to enjoy performances by high-caliber touring musicians who might not otherwise appear locally, expanding access to exceptional artistic experiences. In addition to its cultural impact, the festival increases tourism to Berryville and Clarke County, drawing visitors who support local businesses. It also creates valuable opportunities for regional artisans and vendors to showcase and sell their work, helping them reach new audiences while contributing to a vibrant, arts-centered local economy.

**Please attach the organization's budget.**

Attached as a separate document.

Please select the category that best describes your organization's primary focus.

- Arts Education
- Dance
- Multidisciplinary
- Music
- Opera
- Theater/Storytelling
- Visual Arts
- Other (please describe) While the Watermelon Pickers' Fest is a music festival, there is a large emphasis on music and dance education.

**Populations Benefitted**

Please select any categories that, by your best estimate, will make up 25% or more of the population that will directly benefit from the award during the period of support.

**Racial or Ethnic Groups**

- American Indian/Alaskan
- Asian/Pacific Islander
- Black/African American
- Hispanic/Latino
- White/Caucasian
- Other

This is a community event intended for patrons of all ages and ethnic groups. It is designed to bring diverse people together in a positive way.

**Other Distinct Groups**

- Individuals with disabilities
- Individuals in institutions (hospitals, hospices, assisted care, etc.)
- Individuals below the poverty line
- Individuals with limited English proficiency
- Military veterans/active duty personnel
- Youth at risk

**Age**

- Children/Youth (0-18 years)
- Adults (25-64)
- Young adults (19-24 years)
- Older adults (65+ years)

**Arts Education** Choose the one item which best describes the funded activities.

- 50% or more of the funded activities are arts education directed to K through 12 students, higher education students, pre-kindergarten children, and/or adult learners (including teachers and artists)
- Less than 50% of the funded activities are arts education directed to K through 12 students, higher education students, pre-kindergarten children, and/or adult learners (including teachers and artists)
- None of the funded activities involve arts education

*Stacey Sinclair*

2/15/2026

Signature

Date

# Watermelon Pickers' Fest – 2026 Project Budget Summary

## Projected Income

- Ticket Sales: \$125,000  
Camping Fees: \$30,000
- Grants & Sponsorships: \$20,000
- Merchandise / Food & Beverage Sales: \$6,000

**Total Projected Income: \$181,000**

## Projected Expenses

**Artist Fees (Performances & Contests) – \$78,050**

**Arts Education & Community Programming (Workshops & Youth Programming) – \$4,500**

- Instrumental Workshops
- Kids Academy Programming
- Harmony Singing & Dance Workshops
- Youth Activities

**Site & Event Logistics (Facility, Sanitation, Safety, Insurance, Equipment) – \$42,210**

**Production (Sound, Hospitality, Lodging, Marketing & Administrative Costs) – \$38,605**

**Staffing (Operations, Stage Management, Volunteer Coordination, Merch & Guest Services) – \$7,900**

**Merchandise Production Costs – \$4,100**

**Advertising & Promotion – \$5,775**

**Total Projected Expenses: \$176,640**

**Grant Request: \$4,500**

The requested grant funds will directly support the Arts Education & Community Programming component of the festival, including hands-on instrumental workshops, youth music programming, and participatory dance instruction, open to attendees of all ages and experience levels.

